

ISI-LPS Series

Standard Transfer Central Inverter



Inverter Systems, Inc.

WWW.INVERTERSYSTEMSINC.COM

MINI EMERGENCY POWER SOURCE 750, 950, AND 1150

For LED, Fluorescent, Incandescent, and Electronic Low Voltage



UL 924 Listed
Self-Testing
Self-Diagnostic



Less Than
1.0 second
Transfer Time



UL Listed
for Damp
Locations



NFPA 101
Life Safety
Code



Buy
American Act
Compliant



OPERATION

The Upon failure of the normal utility power the LPS unit is automatically turned on by a solid state switching circuit and provides a minimum of 90 minutes of emergency power to the connected load. Lumen output will be maintained at 100% of the lamp's rating throughout the entire duration.

A solid state low voltage disconnect circuit is used to protect the battery from being severely damaged by a deep discharge. When normal utility power is restored, the unit switches the load back to normal utility operation and the fully automatic, temperature, compensated, dual mode charger begins to restore the battery; bringing it to full charge within UL924 specification.

SYSTEM STATUS MONITORING PANEL

The unit is provided with a monitoring panel on the front. The panel provides a test switch for user initiated system tests and a 3-LED array that provides visual indication.

IMPROVED AESTHETICS

The system's sinusoidal output eliminates voltage drop and proximity concerns. This provides installation capabilities for units installed 100 feet from the unit.

SYSTEM ADVANTAGES

Compared to traditional discrete emergency lighting units, the LPS Series provides emergency illumination from a single power source resulting in lower maintenance overhead and routine testing expenses. LPS units lower installation costs by powering existing lighting fixtures during emergencies. And because connected fixtures are driven at full, they provide far superior egress lighting and improved occupant safety.

WARRANTY / LISTING

- Unit: (Excluding lamps) Full coverage against defects in materials and workmanship for 3 years from date of shipment
- Battery: 3 years full warranty plus an additional 7-years of pro-rata coverage
- All models are UL924 listed and meets NFPA 101 Life Safety Code, NEC, OSHA, Local, and State codes.
- UL Listed for Damp Locations (20° - 30°C)
- Certified to CEC Under Title 20 Regulations
- FCC Part 15 Class A Compliant

STANDARD FEATURES

- For incandescent, fluorescent, induction, and LED fixtures
- 98% Efficiency Rating at full rated load (line)
- Input Surge Protection: Meets UL924
- Less than 1.0 second transfer time
- Housing: Scratch and corrosion resistant heavy duty steel cabinet finished in white baked-on powder paint.
- Sinusoidal output eliminates compatibility problems
- "Soft Start" design reduces fixture inrush current
- Compatible with dimming ballasts
- Normally-ON and/or Normally-OFF output
- Provision for switching capability - always on during emergency conditions regardless of local switch position
- Long life, maintenance-free lead-calcium battery
- Runtime: 90-minutes standard. Other runtime available, consult factory.

SPECIFICATIONS

- Input Voltage: 120 or 277 VAC $\pm 10\%$ (Field selectable)
- Frequency: 60 Hz ($\pm 2\%$ at Input, $\pm 0.3\text{Hz}$ at Output)
- Input Protection: Provided by Service Panel rated at 20 amps maximum
- Output Voltage: 120 or 277 VAC
- Output Distortion: Less than 3% THD (linear load)
- Output Distortion: Less than 3% THD (linear load)
- Output Protection: Breaker and overload shut down protection.
- Waveform: Sinusoidal (digitally controlled)
- Static Voltage: $\pm 5\%$ during battery discharge. 0-100% linear load
- Load Power Factor Range: 0.88 Lead to 0.88 Lag
- Minimum Loading: 0% of rated system capacity

ISI-LPS SERIES

Standard Transfer Central Inverter
750VA/W, 950 VA/W, 1150 VA/W



Inverter Systems, Inc.

WWW.INVERTERSYSTEMSINC.COM

ORDERING GUIDE

EXAMPLE MODEL # ISI-LPS-1150-OCB3-4AO-SDT

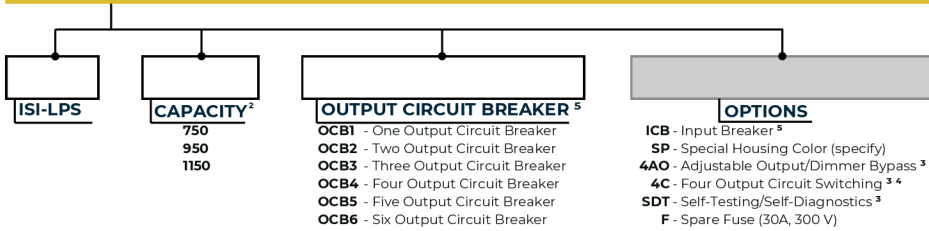

1. Other options available
2. Some options may impact product UL listing. Consult factory.
3. For more information, separate specification sheets are available on the -4AO, -4C and -SDT options. Consult factory. 4AO covers all 4C features plus dimming module.
4. Not available together.
5. Total number of Circuit breakers not to exceed six (6). Breaker size is 10 amperes.

= Required feature for part number.

= Optional feature. Not required for part number.

STANDARD WIRING DIAGRAM:

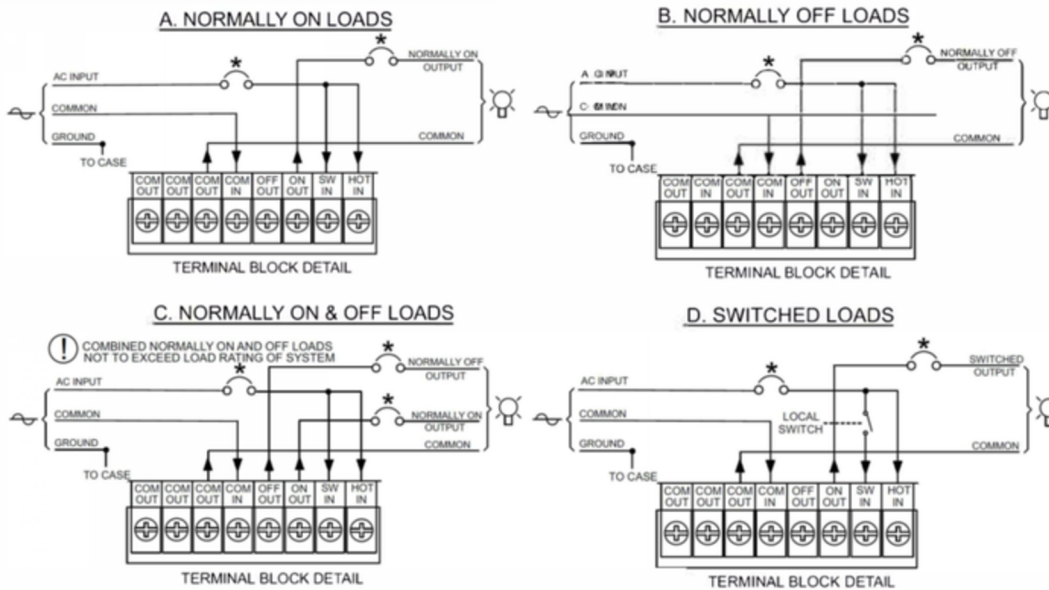

- NOTES:**
- INPUT SUPPLY FROM UNSWITCHED UTILITY RATED 20 AMPS MAXIMUM.
 - OUTPUT(S) TO LIGHTING LOADS
 - AVAILABLE WITHIN UNIT AS OPTION

VOLTAGE SELECTION

DETAIL:

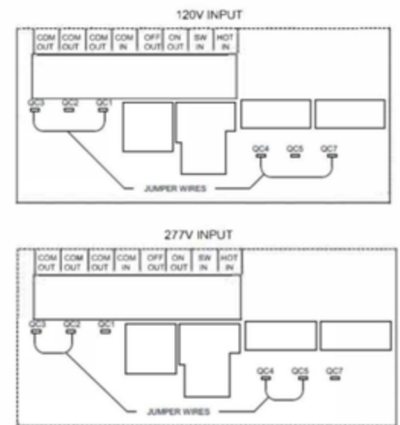

NOTE:
Factory terminated jumper wires are provided with LPS Systems for making user selected input/output voltage connections.

GENERAL SPECIFICATIONS

Electronics Module						Battery								
Partial Model Number	Power Rating (VA / W)	System Efficient (Full Load)	System Weight (lbs./kg.)	THERMAL OUTPUT (BTUs)		AC INPUT CURRENT		Number of Battery Strings	Number of Batteries	Voltage (VDC)	Battery Current (amps)	Housing Dimensions		
				ONLINE	EMERGENCY	120 VAC	277 VAC					LENGTH	HEIGHT	DEPTH
LPS-750	750	98%	190/86.2	14	416	7.53	3.26	2	8	48	18.2	22.4"	25.1"	9.2"
LPS-950	950	98%	222/100.7	18	484	8.45	3.66	2	10	60	18.2	22.4"	25.1"	9.2"
LPS-1150	1150	98%	254/115.2	22	535	10.2	4.42	2	12	72	18.2	22.4"	25.1"	9.2"