

Installation And Operation Instructions

For LPS Series Inverter Power Systems

LPS-750, LPS-950 AND LPS-1150

***True
Sinusoidal
Output Power***



READ AND FOLLOW ALL SAFETY INSTRUCTIONS

IMPORTANT SAFEGUARDS

When using electrical equipment, basic safety precautions should always be followed, including the following:

READ AND FOLLOW ALL SAFETY INSTRUCTIONS:

- *Do not use outdoors.*
- *Do not let power supply cords touch hot surfaces.*
- *Do not mount near gas or electric heaters.*
- *Use caution when servicing batteries. Battery acid can cause burns to skin and eyes. If acid is spilled on skin or in eyes, flush acid with fresh water and contact a physician immediately.*
- *Equipment should be mounted securely in locations and at heights where it will not be readily subjected to tampering by unauthorized personnel.*
- *The use of accessory equipment not recommended by the MANUFACTURER may cause an unsafe condition.*
- *The AC voltage rating of this equipment is specified on the product label. Do not connect equipment to any other voltage.*
- *Do not use this equipment for other than its intended purpose.*
- *Servicing of this equipment should be performed by qualified service personnel.*

SAVE THESE IMPORTANT SAFETY INSTRUCTIONS

The installation and use of this product must comply with all national, federal, state, municipal, or local codes that apply.

Please read this manual thoroughly before operating the LPS Inverter System.

CAUTION:

This equipment provides reduced current levels when higher voltage loads are connected. The derangement signal requires calibration to ensure proper operation.

Table of Contents

Description

Page

Section 100

System Installation Instructions

| | | |
|--------------|--|-----------|
| 101. | Specifications..... | 4 |
| 102. | Receiving, Moving and Storing Systems and Batteries | 5 |
| 102.1 | Shipping Damage | 5 |
| 102.2 | Temporary Storage of Units and Batteries | 5 |
| 103. | Installation Requirements | 5 |
| 103.1 | Operating Environment..... | 5 |
| 103.2 | High Altitude Operation | 5 |
| 104. | Cabinet Mounting | 5 |
| 104.1 | Tools Required | 5 |
| 104.2 | Mounting Hardware..... | 6 |
| 104.3 | Knockout Locations..... | 6 |
| 104.4 | Cabinet Mounting..... | 6 |
| 105. | AC Connections | 6 |
| 105.1 | AC Wiring Preparations | 7 |
| 105.2 | AC Input Voltage Selector Plug Installation | 7 |
| 105.3 | AC Input/output Wiring Connections to Terminal Block | 7 |
| 106. | Battery Information..... | 10 |
| 106.1 | Tools..... | 10 |
| 106.2 | Battery installation and Connection | 11 |
| 106.3 | Battery Voltage Check | 12 |
| 107. | Final Installation Checklist | 12 |
| 108. | System Start-Up Procedure | 13 |
| 109. | System Test | 13 |
| 110. | System Self Test / Diagnostics | 13 |
| 110.1 | Self Test / Diagnostic Functions | 14 |
| 110.2 | Self Test / Diagnostic Indication..... | 14 |

Section 200

Maintenance

| | | |
|--------------|--|-----------|
| 200.1 | Safe Shut Down Procedure | 14 |
| 200.2 | Routine System Maintenance..... | 15 |
| 200.3 | Manual Routine Inverter Tests | 15 |
| 200.4 | Routine Battery Inspection and Maintenance | 15 |
| 200.5 | Battery Replacement Procedure..... | 15 |
| 200.6 | Battery Disposal..... | 15 |

Section 100 System Installation Instructions

101 Specifications

Input

- Input voltage: Universal 120 or 277Vac.
- Input frequency: 60HZ ±2%
- Input surge protection: Meets UL 924

Output

- Output voltage: Universal 120 or 277Vac, 60HZ. Other voltages available upon request
- Output regulation: (static) ±5% based on a 0% - 100% resistive load
- Minimum loading: none required
- Output distortion: Less than 3% THD linear load
- Load power factor: .88 lead to .88 lag
- Output frequency: ±0.3 Hz during emergency
- Time to transfer to inverter after a utility power failure: <1 second

Battery

- Battery type: Maintenance free sealed Lead Calcium
- Battery charger: Fully automatic dual-mode with temperature compensation
- Recharge time: Meets UL requirements (96 Hours)
- Battery protection: Automatic low-battery voltage disconnect and reverse polarity protection.
- Standard batteries: Sealed Lead-Calcium: 7-year life
- Battery voltage: 48Vdc, 60Vdc or 72Vdc (depends on model)
- Runtimes: 90 minutes standard.
- Operating temperature: 20°C to 30°C (68°F to 86°F)

- Relative humidity: 95% non-condensing

Note: Lead Calcium battery performance rated at 25°C (77°F) for load.

Table 1 (Electrical & Physical Specifications)

* System weights shown include installed batteries

| MODEL NUMBER | INPUT/OUTPUT VOLTAGE | CAPACITY FOR 1 1/2 HRS. WATTS/VA | SYSTEM WEIGHT | | SYSTEM EFFICIENCY (FULL LOAD) | NUMBER OF BATTERIES | NUMBER OF BATTERY STRINGS | BATTERY VOLTAGE (VDC) | BATTERY CURRENT (ADC) | AC INPUT | | | THERMAL OUTPUT (BTUs) | | HOUSING DIMENSIONS | | |
|--------------|----------------------|----------------------------------|---------------|-------|-------------------------------|---------------------|---------------------------|-----------------------|-----------------------|----------|---------|---------|-----------------------|-----------------|--------------------|----------------|--|
| | | | LBS. | KG. | | | | | | 120VAC | 277 VAC | ON-LINE | EMERGENCY | LENGTH | HEIGHT | DEPTH | |
| LPS-750 | 120/277 VAC | 750/750 | 190 | 86.2 | 98 % | 8 | 2 | 48 | 18.2 | 7.53 | 3.26 | 14 | 416 | 22.4" (56.9 cm) | 25.1" (63.8 cm) | 9.2" (23.4 cm) | |
| LPS-950 | 120/277 VAC | 950/950 | 222 | 100.7 | 98 % | 10 | 2 | 60 | 18.2 | 8.45 | 3.66 | 18 | 484 | 22.4" (56.9 cm) | 25.1" (63.8 cm) | 9.2" (23.4 cm) | |
| LPS-1150 | 120/277 VAC | 1150/1150 | 254 | 115.2 | 98 % | 12 | 2 | 72 | 18.2 | 10.2 | 4.42 | 22 | 535 | 22.4" (56.9 cm) | 25.1" (63.8 cm) | 9.2" (23.4 cm) | |

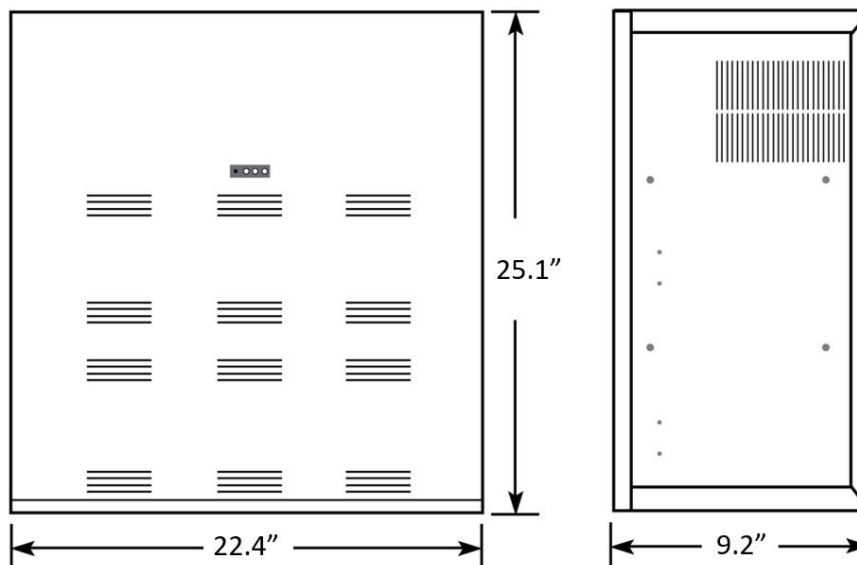

102. Receiving, Moving and Storing Systems and Batteries

102.1 Shipping Damage

Inverter system batteries are shipped separately.

Carefully inspect all cartons upon receipt for evidence of shipping damage.

Notify carrier immediately of leaking or damaged cartons for possible concealed damage.

102.2 Temporary Storage of Units and Batteries

For temporary storage of **LPS** inverter systems and batteries prior to installation, select a clean, cool, dry location with normal ventilation for human habitation and level floors.

Storage Temperature:

Store all batteries at 0° to +40° C (32° to +104° F). Batteries will have a longer shelf life if stored at 15° C (60° F). The **LPS** electronics and battery cabinets may be stored at -20° to +60° C (-4° to +140° F).

IMPORTANT:

Lengthy storage of batteries will cause irreversible damage to the cells.

*Failure to connect **LPS** inverter system batteries to an energized charging circuit within 90 days from the date of shipment will void the battery warranty.*

DANGER: Explosive - Can Cause Blindness Or Other Severe Injuries

Every type of battery can produce hydrogen gas, even sealed, maintenance-free batteries. The gas is vented through the vent caps and into the air. Do not allow smoking, sparks, or flames in battery storage location because hydrogen is concentrated under the vent cap of each cell of the battery. Hydrogen is highly explosive, and is hard to detect because it is colorless, odorless, and lighter than air.

103. Installation Requirements

103.1 Operating Environment

Install the **LPS** inverter system in a clean, cool, dry place with normal ventilation for human habitation and in such a location to hamper vandalism but allow easy access for testing and maintenance.

Operating Temperature:

***LPS** inverter Systems are UL Listed for 20° to 30° C (+ 68° to +86° F) operation.*

Battery performance and service life is maximized if the operating temperature is maintained at 25° C (77° F).

Temperature Effect On Lead Calcium Battery Performance:

Lead Calcium batteries will be less efficient at temperatures below 20° C (68° F), and high temperatures will reduce battery life. Typically, at 35° C (95° F), battery life will be half of what it would be at normal temperature of 25° C (77° F). At 45° C (113° F), battery life will be one-fourth of normal.

Ventilation:

*The air around the unit must be clean, dust-free, and free of corrosive chemicals or other contaminants. Do not place the **LPS** inverter system or batteries in a sealed room or container.*

CAUTION: Never Install Batteries in A Sealed Room Or Enclosure

103.2 High Altitude Operation:

The maximum operating temperature drops 1° Celsius per 300 meters (2° F per 1000 feet) above sea level. Maximum elevation is 3000 meters (10,000 feet).

104. Cabinet Mounting

104.1 Tools Required

The following tools are required to install the system:

Socket Set, Phillips Screwdriver, Diagonal Wire Cutters, Long Nose Pliers, Electrical Tape, Digital Volt-Ohm Meter, Safety Glasses with Side Shields, Small Punch (knockout removal), Hammer, Electric Drill, Wood or Masonry Bits, Level.

104.2 Mounting Hardware

Mounting hardware is not provided. Care should be taken when selecting mounting hardware to assure that it is the proper type for the application and sized to safely support the systems full weight when installed assuring safe and secure attachment of system to wall surface or building structures. For ease of installation, the factory recommends that the head size of mounting screws or bolts be small enough to pass through the keyhole knockouts provided for mounting. This will allow the unit to be hung on partially installed mounting hardware and facilitate easy cabinet removal if ever necessary.

104.3 Knockout Locations

All models provide knockouts on the top of the unit.

Additional entry points, if required can be added using a metal punch. Do not drill into the cabinet as metal filings can cause short circuits and damage the equipment.

NOTE: Consider unit knockout locations prior to mounting unit. Allow room for easy routing of conduit to entry point.

104.4 Cabinet Mounting:

- 1) Remove cover and any packing material inside unit housing that may have been used for shipping purposes.
- 2) Remove the appropriate knockouts, 7/8" or 1-1/8" diameter, on the top of the unit housing to facilitate conduit attachment. Also remove keyhole knockouts in the upper and lower corners on the back of the housing.
- 3) Secure housing to mounting surface through all keyhole knockouts provided using mounting hardware (not supplied) sized appropriately to support the unit weight.

105. AC Connections

CAUTION:

- A) **LPS** inverter system units contain hazardous AC and DC voltages. Because of these voltages, a qualified electrician must install the **LPS** inverter system, AC line service, and batteries. The electrician must install the AC line service according to local, state and NEC codes and must be familiar with batteries and battery installation.
- B) Before installing, maintaining, or servicing the unit, always remove or shut off all sources of AC power to the **LPS** inverter system. Turn unit battery circuit breaker (CB-1) off to make sure the unit will not supply output voltage. Turn unit AC input breaker (CB-2) off (if provided). Turn the AC line input circuit breaker **OFF** at the service panel.
- C) Whenever AC and/or DC voltage is applied, there will be AC voltage inside the **LPS** inverter system unit; the unit can supply power from AC line or from its batteries. To avoid equipment damage or personal injury, always assume that there may be voltage inside the **LPS** inverter system.
- D) Remove rings, watches, and other jewelry before installing the AC wiring. Always wear protective clothing and eye protection and use insulated tools when working near batteries. Whenever servicing an energized unit with the inside panel open, electric shock is possible; follow all local safety codes. **TEST BEFORE TOUCHING!**
- E) To reduce the risk of fire or electric shock, install the **LPS** inverter system and the batteries in a temperature-controlled and humidity-controlled indoor area free of conductive contaminants. See **Section 103** for operating environment specifications.

105.1 AC Wiring Preparations

1. Remove the system's front cover.
2. Make sure the **LPS** inverter system input and output voltages are correct for the particular application. Remember that the **LPS** system provides single-phase power only.
3. The input circuit breaker in the input service panel provides the means for disconnecting AC to the **LPS** inverter system. Only authorized persons shall be able to disconnect AC to the unit. (See **NEC 700-20** and **700-21**.)

CAUTION: To prevent electrical shock or equipment damage, for all units, make sure the LPS Battery is disconnected and the AC input circuit breaker at the service panel is OFF before making AC connections to the LPS inverter system.

4. If not previously done, remove cabinet knockouts for AC Input and AC Output as described in **Sections 104-4, 104.5** or **104.6** depending on mounting method

CAUTION: Do not drill the cabinet; drill filings may damage the unit and prevent it from operating. If larger knockouts are needed, use a chassis punch to enlarge the appropriate knockout. Do not add additional or unnecessary knockouts.

5. Install the input and output conduits.
6. Run the AC Input service conductors and AC Output conductors through separate conduits. **LPS** inverter system emergency output circuits shall be installed in dedicated conduit systems and not shared with other electrical circuits as described in **NEC 700-9(b)**.

LPS models can be configured for either 120Vac or 277Vac input connections as well as various modes of output operation as described in this section. Refer to the appropriate wiring diagrams to properly connect the utility AC power, fixtures and external switching or dimming device (where applicable). Perform all wiring procedures in accordance with applicable codes.

105.2 AC Input Voltage Selector Plug Installation

LPS inverter systems may be operated from either 120Vac or 277Vac power sources. Determine the actual AC input line voltage and install the provided Voltage Selector Jumpers in the position next to the system terminal block that matches the line voltage potential as shown in the illustration below.

NOTE:

Factory terminated jumper wires are provided with **LPS** Systems for making user selected input/output voltage connections.

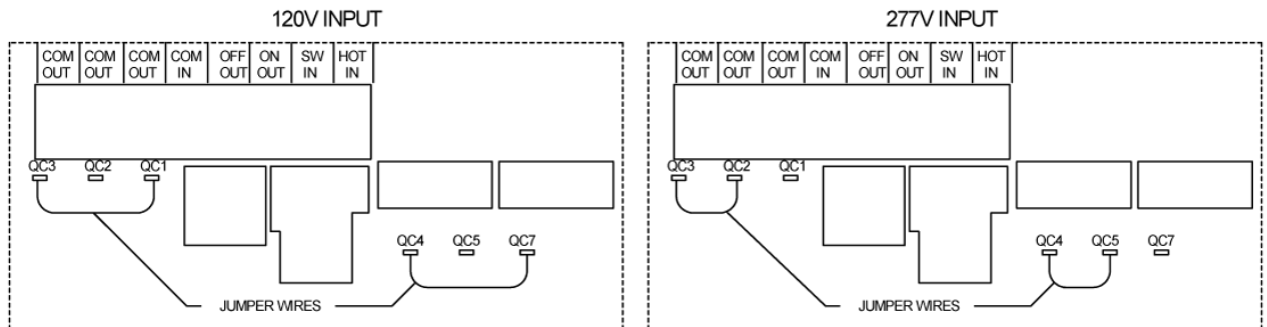

CAUTION: Failure to install the Voltage Selector Jumpers will prevent system operation. Installing the Voltage Selector Jumpers in the position that does not match the actual AC input line voltage will damage the unit, void the warranty and may cause a dangerous or unsafe condition.

105.3 AC Input/Output Wiring Connections to Terminal Block

Depending on how the fixture load is to be operated, wire the system as described below.

Normally-On Operation - Connected fixture(s) remain illuminated in AC and emergency modes.
See **Wiring Diagram A**.

Normally-Off Operation - Connected fixture(s) illuminate only upon loss of utility AC power.
See **Wiring Diagram B**.

Normally-On and Normally-Off Operation - A combination of the operating modes described above.
See **Wiring Diagram C**.

Switched Load Operation - Single Circuit - Connected fixture(s) can be extremely switched and will illuminate upon loss of utility AC power regardless of external switch position.
See **Wiring Diagram D**.

CAUTION: If the Inverter being used has a **-4C** or **-4AO** option, then please refer to wiring diagrams **E, F** or **G**.

A. NORMALLY ON LOADS

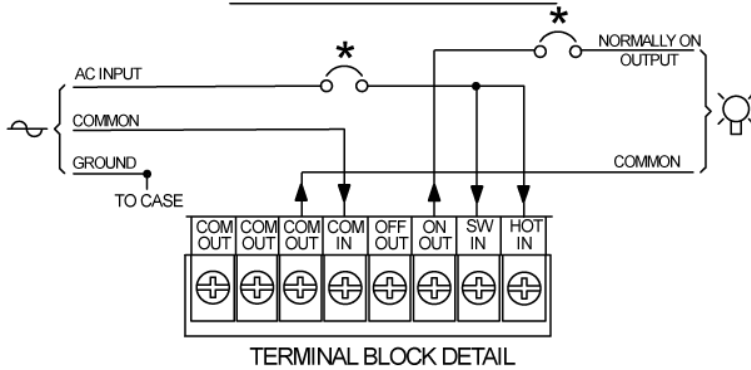

B. NORMALLY OFF LOADS

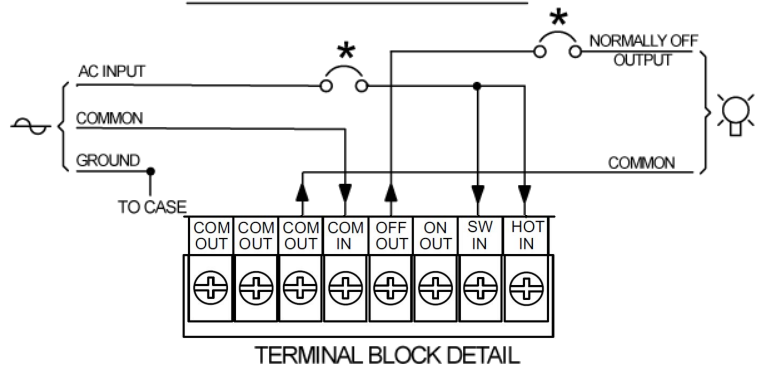

C. NORMALLY ON & OFF LOADS

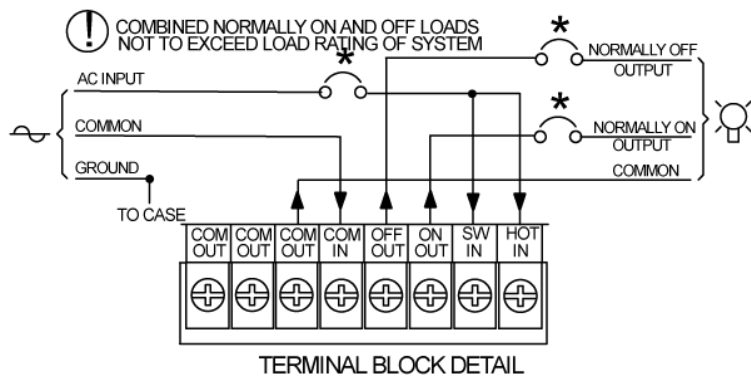

D. SWITCHED LOADS

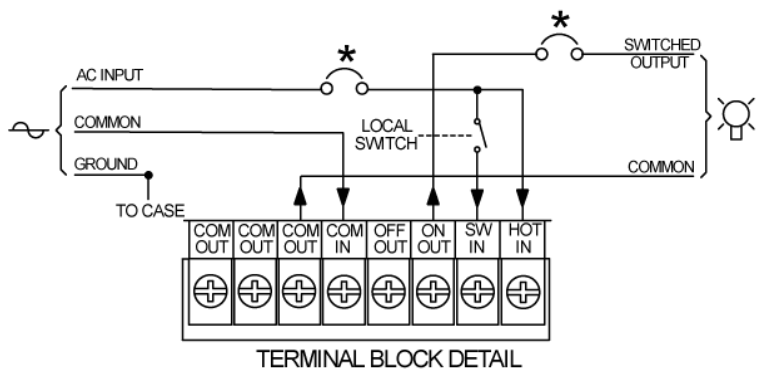

NOTES:

- ⚡ INPUT SUPPLY FROM UNSWITCHED UTILITY RATED 20 AMPS MAXIMUM.
- 💡 OUTPUT(S) TO LIGHTING LOADS
- * AVAILABLE WITHIN UNIT AS OPTION

E. SWITCHED OR DIMMED EMERGENCY LOADS

NOTE: ONLY (2) OF (4) POSSIBLE SWITCHED OR DIMMED CIRCUITS SHOWN

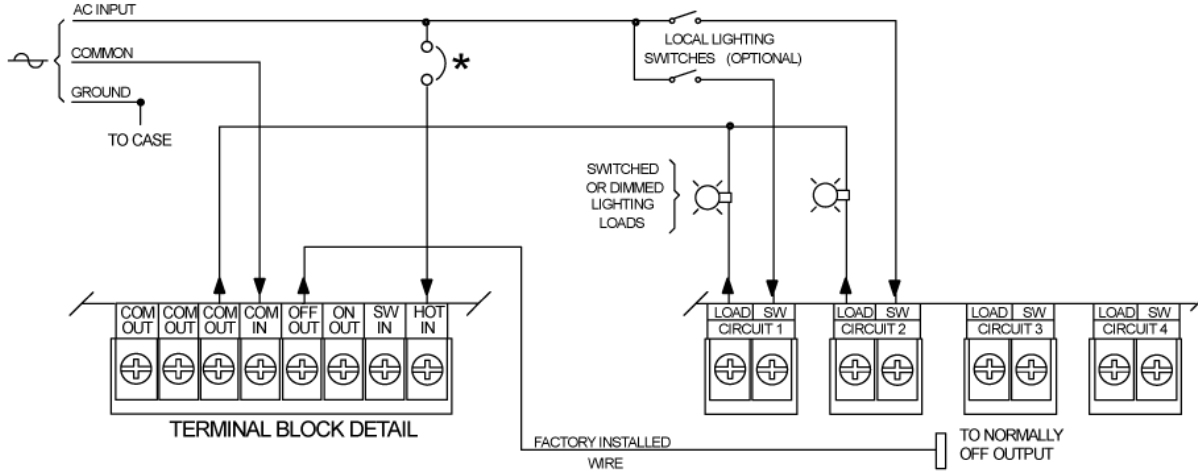

F. SWITCHED OR DIMMED AND UNSWITCHED EMERGENCY LOADS

NOTE: ONLY (2) OF (4) POSSIBLE SWITCHED OR DIMMED CIRCUITS SHOWN

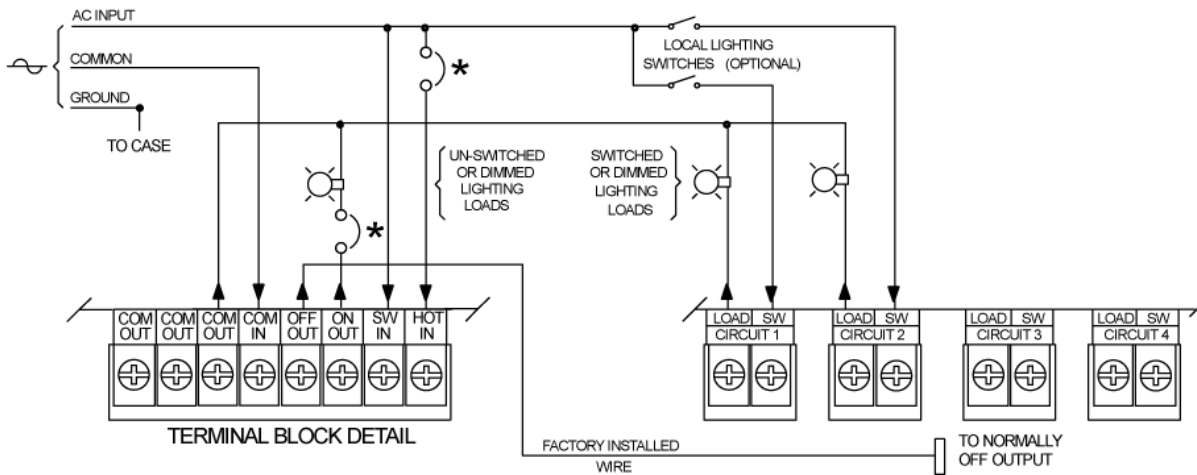

G. DIMMING OPTION CONTROL WIRING

NOTE: ONLY (1) OF (4) POSSIBLE CIRCUITS SHOWN

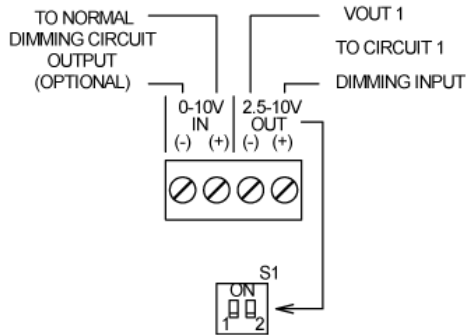

DIMMING OPTION PROGRAMMING TABLE

NOTE: POSITION-1 AND POSITION-2 ARE PROVIDED FOR EACH OF THE (4) CIRCUITS.

| POSITION-1 | POSITION-2 | VOUT 1 |
|-------------|-------------|--------|
| OPEN (OFF) | OPEN (OFF) | 10.0V |
| OPEN (OFF) | CLOSED (ON) | 7.50V |
| CLOSED (ON) | OPEN (OFF) | 5.00V |
| CLOSED (ON) | CLOSED (ON) | 2.50V |

NOTE: Dimming switches S1-1 and S1-2 are designed for independent settings to allow different emergency dimming control voltages for each circuit

CAUTION: Dimming switches must be programmed such that total loads do not exceed unit rating in emergency mode.

NOTES:

⚡ INPUT SUPPLY FROM UNSWITCHED UTILITY RATED 20 AMPS MAXIMUM.

💡 OUTPUT(S) TO LIGHTING LOADS

* AVAILABLE AS AN OPTION

106. Battery Information

Important Safety Precautions

The installer must take these precautions:

- 1) *Wear protective clothing, eye-wear, rubber gloves and boots. Batteries contain corrosive acids or caustic alkalis and toxic materials and can rupture or leak if mistreated. Remove rings and metal wristwatches or other metal objects and jewelry. Don't carry metal objects in pockets where the objects can fall onto the batteries or into the **PS** inverter system.
Tools must have insulated handles so that they will not short battery terminals. Do not allow a tool to short a battery terminal to another battery terminal or to the cabinet at any time. Do not lay tools or metal parts on top of the batteries, and do not lay any objects where they could fall onto the batteries or into the cabinet.*
- 3) *Install the batteries as described in this manual. When connecting cables, never allow a cable to short across a battery's terminals or to the cabinet.*
- 4) *Keep the cable away from any sharp metal edges.*
- 5) *Install the battery leads so they cannot be pinched by the **LPS** inverter system cover/door.*
- 6) *Where conductors may be exposed to physical damage, protect conductors in accordance with **NEC** requirements.*
- 7) *Full voltage and current are always present at the battery terminals. The batteries used in this system can produce dangerous voltages, extremely high currents, and possible risk of electric shock. Batteries may cause severe injury if the terminals are shorted together or to ground (earth). Be extremely careful to avoid electric shock and burns caused by contacting battery terminals or shorting terminals during battery installation. Do not touch uninsulated battery terminals.*
- 8) *A qualified electrician who is familiar with battery systems and required precautions must install and service the batteries. Any battery used with this unit shall comply with the applicable requirements for batteries in the standard for emergency lighting and power equipment, UL 924. Cabinets are designed to be used with, and batteries must be replaced by identical cells or a Manufacturer approved equivalent. If using substitute batteries not supplied by the Manufacturer, the unit's UL listing will be void, and the equipment may fail to perform properly. The installation must conform to national and local codes as well. Keep unauthorized personnel away from batteries.*

106.1 Tools

The following tools are required to install the system batteries:

Long Nose Pliers, Digital Volt-Ohm Meter, Safety Glasses

CAUTION: Always use insulated tools for battery installation.

106.2 Battery Installation and Connection

Battery Placement:

The LPS-750, LPS-950, and LPS-1150 models are all provided with (2) parallel battery strings. The 1st string is located in the upper battery compartment, the 2nd string is located in the lower battery compartment. Batteries should be carefully placed in the battery compartments with the positive (+) red terminals facing upwards and outwards. Position batteries in the central location towards rear of the compartments.

LPS-750: Place (4) batteries in each compartment.

LPS-950: Place (5) batteries in each compartment.

LPS-1150: Place (6) batteries in each compartment.

Carefully install battery retention brackets in each compartment with the supplied hardware.

Battery installation on the 750W model (for reference)



Battery retention brackets installed on the front

Battery Wiring:

CAUTION: To prevent possible damage to the unit when connecting batteries, verify that the unit battery circuit breaker CB-1 is in the OFF position.

Connect batteries with supplied wiring jumpers using hardware provided with batteries. For LPS-750 refer to Battery Wiring Diagram #1. For LPS-950 refer to Battery Wiring Diagram #2. For LPS-1150 refer to Battery Wiring Diagram #3.

Battery Chart:

| <u>Model System</u> | <u>DC Voltage</u> | <u>Number of Batteries</u> | <u>Battery Part Number</u> | <u>Battery Wiring Diagram</u> |
|---------------------|-------------------|----------------------------|----------------------------|-------------------------------|
| LPS-750 | 48 | 8 | INV-03-005 | 1 |
| LPS-950 | 60 | 10 | INV-03-005 | 2 |
| LPS-1150 | 72 | 12 | INV-03-005 | 3 |

IMPORTANT: Observe correct polarity on battery terminals

BATTERY WIRING DIAGRAM 1 (48VDC)

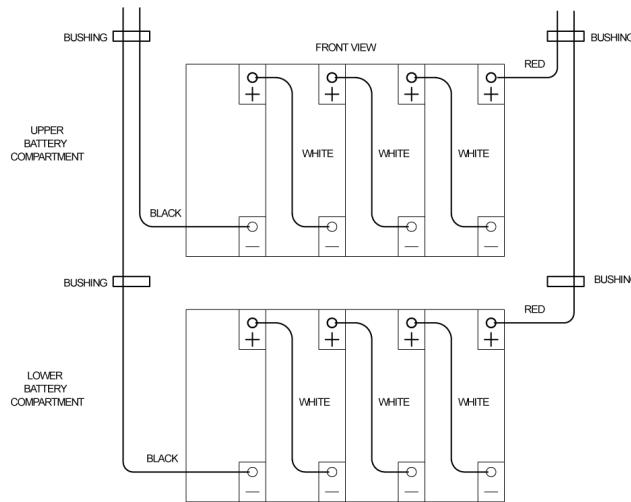

BATTERY WIRING DIAGRAM 2 (60VDC)

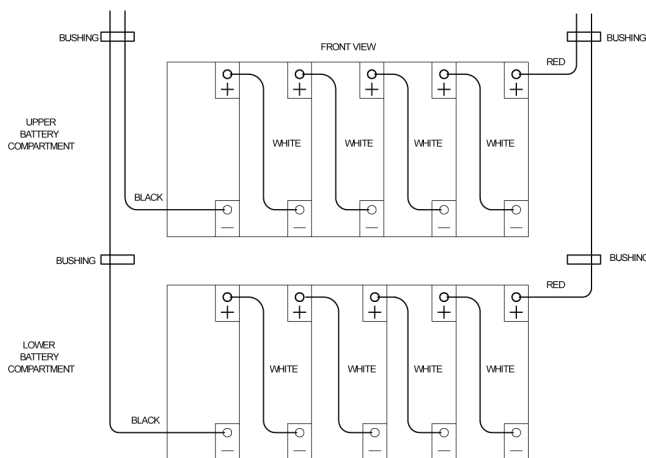

BATTERY WIRING DIAGRAM 3 (72VDC)

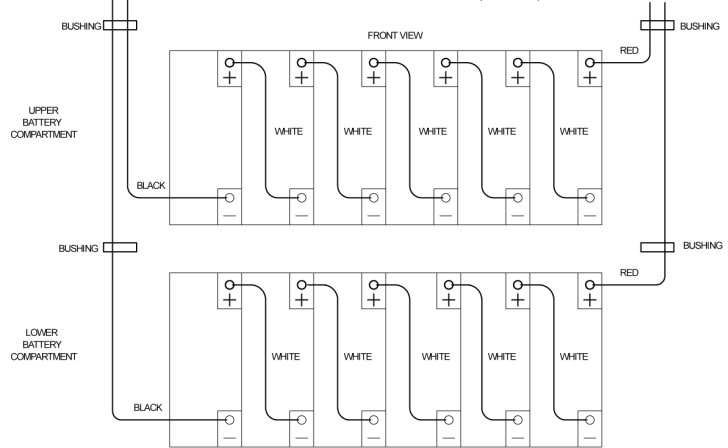

106.3 Battery Voltage Check

Using a digital volt-ohm meter, check for correct nominal battery voltage between DC Input NEG and POS wires. Voltage reading should be $\pm 10\%$ of system's nominal 48Vdc for LPS-750, 60Vdc for LPS-950 operating voltage or 72Vdc for LPS-1150 operating voltage.

107. Final Installation Checklist

IMPORTANT: Before proceeding to the System Start-Up Procedure (Section 108) complete the Final Installation Checklist below.

1. Insure the LPS cabinet is securely fastened to a wall or other structure.
2. Insure that the input circuit breaker in the building service panel serving as the AC disconnect to the LPS system is in the **OFF** position. Insure that both AC input and output breakers (if provided) is in the off position.
3. Check for proper ground connections in the **LPS** unit cabinet.
4. Check for any loose wiring connections in the **LPS** unit cabinet.
5. Check that correct nominal battery voltage (48Vdc for LPS-750, 60Vdc for LPS-950, and 72Vdc for LPS-1150) is present in the **LPS** unit between the battery's **NEG** and **POS** end terminals.
6. Verify AC Input Voltage Selector Jumpers are installed and in the proper position to accept the AC input line voltage. system voltage configuration.

CAUTION: Failure to install the Voltage Selector Jumpers will prevent system operation. Installing the Voltage Selector Jumpers in the position that does not match the AC input line voltage will damage the unit, void the warranty and may cause an dangerous or unsafe condition.

108. System Start-Up Procedure

IMPORTANT: The LPS inverter system is a sophisticated electronic backup power supply. Care must be taken to follow the steps below in their exact sequence. Failure to do so may result in possible equipment failure.

CAUTION: Familiarize yourself with the shut down procedure in Section 200.1 before proceeding with the LPS system Start Up.

1. Hold S-1 Pre-charge Switch in the on(up) position for 15 seconds then release.
2. Place battery circuit breaker (CB-1) in the on position.
3. Apply utility AC power to the system by turning the branch circuit breaker in the main power panel to the ON position. Place AC input breaker CB-2 (if provided) in the on position. Place AC output breakers (up to (6) if provided) in the on position.
4. Observe the LED Status indicators and verify the following:
 - A) **AC ON** indicator (red LED) is illuminated (indicates AC utility power is available to unit).
 - B) **CHG ON** indicator (green LED) is illuminated (indicates battery is connected and charger is operational).
 - C) **INV ON** Indicator (yellow LED) will flash if unit detects an overload condition, preventing inverter operation in the event of a failure of utility AC power or operation of the Test Switch. Verify load level and reduce to output rating of unit.
5. Verify **Normally-On** fixtures or switched fixtures (where applicable) are illuminated (local fixture switch must be in **ON** position).

109. System Test

Momentarily push **TEST** switch and verify the following:

- A) **INV ON status indicator (yellow) illuminates (indicates inverter is operational).**
- B) **Normally-On, Normally-Off and Switched fixtures are illuminated (where applicable).**

109.2 For SDT version units

These models also provides for manual testing by pushing the TEST button in a specific pattern:

| A) <u>Action</u> | <u>Reaction and LED Indication</u> |
|---|--|
| Push test switch Once (within (2) seconds) | (30) second test: one blink GREEN/pause |
| Push test switch Twice (within (2) seconds) | (30) minute test: two blinks GREEN/pause |
| Push test swithc Three times (within (2) seconds) | (90) minute test: three blinks GREEN/pause |
| Push test switch and hold for (3) seconds | Cancel Test |
| Push test switch and hold for (6) seconds | System reset |

- B) INV ON status indicator (yellow) illuminates (indicates inverter is operational).
- C) Normally-On, Normally-Off and Switched fixtures are illuminated (where applicable)

110. System Self-Test / Diagnostics

Once the system is properly installed in accordance with the installation instructions, and AC power is supplied to the, the dual color (SDT STATUS) LED indicator will illuminate, followed by the amber (INV ON) LED indicator. The dual color LED indicates the unit's status. A steady GREEN LED indicates normal service; A blinking GREEN/RED LED indicates the battery is charging; A blinking RED LED (in different combinations) indicates a service alert. Refer to the INDICATION chart in section 110.2 for details. During loss of normal utility power the dual color LED will not be illuminated. The AMBER (INV ON) LED indicator will be illuminated only during inverter operation initiated by the loss of utility power or during any manual or automatic self-test.

Do not touch components inside the unit. DC voltage is always present at the batteries and battery cables.

110.1 Self-Test/Diagnostic Functions

The self-diagnostic function is factory preset and performs the following:

- A) Continuous monitoring of battery, battery charger and connected loads.
- B) Self-testing and a (30) second discharge with a randomized start (per UL 924, Sec. 30.2), once every (30) days, after normal utility power has been supplied for a minimum of (48) hours.
- C) Self-testing and a (30) minute discharge with a randomized start (per UL 924, Sec. 30.2), once every (180) days, after normal utility power has been supplied for a minimum of (48) hours.
- D) Self-testing and a (90) minute discharge with a randomized start (per UL 924, Sec. 30.2), once every (365) days, after normal utility power has been supplied for a minimum of (48) hours.

110.2 Self-Test/Diagnostic Indication

SDT Status LED Indicator

Green steady

RED/GREEN blinking

GREEN blinking

One blink RED/pause

Two blinks RED/pause

Four blinks RED/pause

Inverter ON Indicator (Yellow)

Steady

Flashing

System Status

Normal Service

High Charge enabled

Test Mode enabled Battery

Charger fault Battery fault or

Unit overload Lamp/Load fault

System Status

Inverter is operational

Inverter is overloaded**

****Inverter operation is disabled (during manual test, self-test or failure of utility power). Reduce load level to output rating of the unit for the inverter to become operational.**

200. Maintenance

200.1 Safe Shut Down Procedure

CAUTION: To avoid possible equipment damage or personal injury, assume that there is AC voltage present inside the LPS inverter system unit any time AC input power or DC battery voltage is applied. The inverter is capable of providing output voltage from the batteries even when there is no AC input line voltage. When AC input voltage is present, the unit can provide output voltage even when the batteries are disconnected.

Do not touch components inside the unit. DC voltage is always present at the batteries and battery cables.

Final Shut Down Procedure

1. Open the unit's front access panel.
2. Place unit battery circuit breaker (CB-1) in the off position. Place unit AC input breaker CB-2 (if provided) in the off position, to make sure the unit will not supply output voltage.
3. Place the **AC Input circuit breaker** at the service panel in the **OFF** position.
CAUTION: HAZARDOUS ENERGY IS STORED IN CAPACITORS INSIDE THE LPS UNIT. AFTER TURNING OFF SWITCHES, ALLOW 5 MINUTES FOR CAPACITORS TO DISCHARGE BEFORE ATTEMPTING ANY SERVICE PROCEDURES.
4. If the service technician does not need to access the inside of the unit, keep the unit's front cover/door closed.
5. If the unit will be shut off for an extended period of time, recharge battery every 60 to 90 days.
CAUTION: The battery will be damaged and the warranty voided if not routinely recharged.
NOTE: To turn power back on, follow the "System Start-up Procedure" outlined in Section 108. Be sure to complete all of the steps to assure the unit will operate properly.

200.2 Routine System Maintenance

The **LPS** inverter system unit is designed to provide years of trouble-free operation. The unit does require some routine attention to assure peak performance. The Manufacturer recommends a Preventative Maintenance check be performed by a qualified service technician at least every six months. The technician must observe important safety precautions while performing the following recommended tasks:

- ***Inspect and clean the unit interiors;***
- ***Inspect all batteries for leaks, case swelling or terminal corrosion;;***
- ***Perform an emergency operation test to check operation of all critical connected loads***

200.3 Manual Routine Inverter Tests

NFPA101 requires that Emergency Lighting Equipment be tested on a monthly basis for a period of at least 5 seconds, and a minimum of 90 minutes once a year. We strongly recommend these guidelines be followed to insure system readiness, and to prolong battery life. The **LPS** system was designed with a front panel test switch to facilitate monthly testing. Simply depress the button and hold to test the inverter at anytime. Once released, the **LPS** will revert back to standby operation. For annual 90-minute discharge or other prolonged tests, simply turn off the AC Input breaker at the service panel.

200.4 Routine Battery Inspection and Maintenance

Sealed Lead-Calcium Batteries

Maintenance-free cells are the most common type of battery used today in standby equipment. By design it is as maintenance free as a battery can be. It is recommended, however, that some simple steps be taken to increase system life and maximize reliability:

- A) A quarterly visual check of the battery should be conducted to look for deformities in the battery case, electrolyte leakage and/or terminal corrosion. Any batteries with these conditions are defective and should be replaced. Any corroded terminals found, regardless how slight, are to be cleaned at once to prevent system failure.***
- B) Once a year, all battery connections should be checked for tightness and cleaned and re-tightened as necessary.***

200.5 Battery Replacement Procedure

WARNING:

Always use the same quantity and type of battery as replacements.

Substituting batteries not supplied by the Manufacturer will void the UL listing of the system and may cause equipment failure. To ensure the superior performance of your **LPS** inverter system and to maintain proper charger operation, replace spent batteries only with those having the same part number, voltage and ampere-hour rating as the original batteries.

1. Follow the proper shut down procedure as described in **Section 200.1**.
2. Carefully disconnect all battery wiring. Remove battery retention bracket(s).
3. Remove the batteries from the cabinet.
4. Install new batteries following the instructions outlined in **Section 106.2**.

200.6 Battery Disposal

WARNINGS:

- ***Do not dispose of batteries in a fire, the batteries could explode.***
- ***Do not open or mutilate batteries.***
- ***Released electrolyte is highly toxic and harmful to the skin and eyes.***

CAUTION: Batteries contain lead or cadmium, depending on model. Many state and local governments have regulations about used battery disposal. Please dispose of the batteries properly.