

MODEL EPC-A-2-D INSTALLATION INSTRUCTIONS

! IMPORTANT SAFEGUARDS !

WHEN USING ELECTRICAL EQUIPMENT, BASIC SAFETY PRECAUTIONS SHOULD ALWAYS BE FOLLOWED, INCLUDING THE FOLLOWING:

READ AND FOLLOW ALL SAFETY INSTRUCTIONS

1. This product can be used with LED, ballast, tungsten, and general use loads.
2. Make sure all connections are in accordance with the National Electrical Code and local regulations.
3. To reduce the risk of electric shock, disconnect both normal and emergency power supplies before servicing.
4. This product is intended to be used to control indoor and outdoor located loads.
5. An unswitched AC power source is required (120-240VAC/277VAC).
6. Do not install near gas or electric heaters.
7. Do not attempt to service a sealed Emergency Power Control. When malfunctioning, return to the manufacturer: LVS, LLC. 15007 Wicks Blvd, San Leandro, CA 94577.
8. The use of accessory equipment is not recommended by the manufacturer and may cause unsafe condition.
9. Do not use this product for other than its intended use.
10. Servicing should be performed by qualified service personnel.
11. Equipment should be mounted in locations and at heights where it will not readily be subjected to tampering by unauthorized personnel.

SAVE THESE INSTRUCTIONS

5-Year Limited Warranty

LVS, LLC. warrants to the original purchaser/user for the published warranty period from the date of shipment that should LVS instruments or equipment prove defective by reason of improper workmanship or material, LVS will repair or replace the same equipment without charge. This warranty does not cover defects or malfunctions arising from improper installation, operation or repair, or neglect, accident, or abuse. LVS will honor its warranty provided the equipment has not been physically damaged or improperly installed or connected. To obtain warranty/repair, the defective product should be shipped freight prepaid within the warranty period to the address below. To the extent permitted by applicable law, all warranties extending beyond repair or replacement as described above are disclaimed, including the implied warranties of merchantability and fitness for a particular purpose. Where applicable law prohibits disclaimers or the implied warranties of merchantability and fitness; those warranties are limited to 12 months from date of shipment. LVS provides a 90 day money back guarantee if equipment does not perform in accordance with LVS published specifications. The liability of LVS and its agents under all warranties is limited to repair and replacement as described herein and under no circumstances shall there be liability for any other kind of loss, damage, or labor, either consequential or for injury to person or property or otherwise.

Electrical Specifications

120-240/277v Sensing Input
120-277V Load Ratings:
16 Amp Electronic Ballast/LED/General Use
5 Amp Magnetic Ballast
1800W(120V)/3000W(277V) Incandescent
Normally Closed Output Contact
Auxiliary N.O. Contact (1A/30VDC)
UL924 Listed (usUL/cUL)



Mechanical Specifications

Hub mount to 1/2" K.O.
Suitable for installation in the plenum
Tested to UL2043 (Plenum Rated)
Shipping Weight: 8 oz Color : Black
Temperature: 0°C-60°C(32°F - 140°F)
Body Size: 3-5/8" x 1-5/8" x 1-3/8" (With Hub/Ears)
Mounted Size: 2-1/2" x 1-5/8" x 1-3/8"
(Without Hub/Ears)



LVS, LLC. 15007 Wicks Blvd., San Leandro, CA 94577-4216
Phone: 510-352-9600 1-800-982-4587
Web: WWW.LVSCONTROLS.COM

Application

In the past, all emergency lights were left on 24 hours a day to meet safety codes. Now you can specify & install a **UL924 Listed Emergency Power Control EPC-A-2-D**, which converts normal light fixtures to approved emergency lights. During normal operation, EPC-A-2-D dims designated emergency lights with the same control as your normal lights. During a utility power interruption, the EPC-A-2-D turns designated emergency lights on, at full brightness, regardless of dimmer position.

Intended for use with switching, 0-10V and DALI/EcoSystem dimming controls.

For Line Voltage Dimmable Loads, use model EPC-D-F-ATS.

Patented Automatic Diagnostic - When the room switch is turned off, EPC-A-2-D tests itself for 2.5 seconds, testing that an emergency power source is available and that the EPC-A-2-D, ballast, and lamps are functioning correctly. This feature eliminates the need for manual monthly testing and is approved for this purpose. This allows installation in any location because the test switch does not need to be accessible. This feature can be disabled in the field by using the "ATS" slide switch.

Fire Alarm / Remote Test Switch - Some applications demand that emergency lighting be activated upon fire alarm, security alarm, or remote test switch activation. The EPC-A-2-D is equipped with a low voltage override input (red jumper). Please visit www.lvscontrols.com/FAI.php for details

Universal Mounting - Unique enclosure permits nipple, fixture, panel, or box mounting.

Junction Box Installation

Can also be nipped on
top of LED luminaire
(1/2" K.O.)

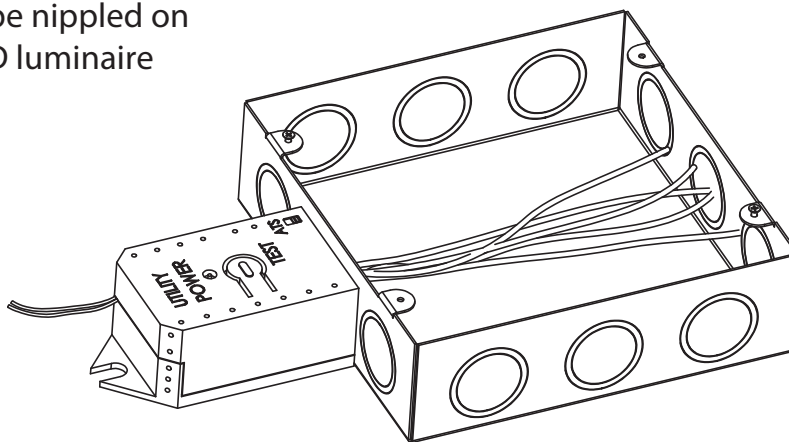

Tested to UL2043,
Plenum Rated

Recommended box size: 4-11/16" , 2-1/8" deep

Installation

In order to install the EPC in accordance with national/local code requirements, a qualified electrician should review & understand the installation instructions. Check voltage & current requirements. Verify & lock out circuit breakers on both regular (utility) power & 24 hour emergency generator or inverter circuit. Install a self-adhesive 2" x 3" caution label in each fixture or load controlled by an EPC cautioning that the load is supplied from 2 different power sources, normal & emergency. Review wiring diagram & connect wires, one at a time, in accordance with the numeric identification. In order to provide a safe light level, when regular power is interrupted, it is recommended that a minimum of approximately 5000 lumen are controlled by a 24 hour emergency circuit & are spaced no farther than 24' in any direction from each other in a normal 9' white ceiling environment.

Initial Testing and Troubleshooting

In a new installation, where hundreds of devices may be used, each having as many as 14 wires to be correctly connected, it is important that a fast, convenient method is used to check connections. In order to test that the wires are connected correctly, without any inconvenience to occupants, do not turn off regular (utility) power off until you have checked each device as follows:

- 1) Check that regular branch circuit breaker is connected & utility power is available. Green LED should be lit. If green LED is not lit, check connections & continuity to branch circuit breaker.
- 2) Check that emergency branch circuit breaker is connected & emergency power is available.
- 3) Normal Operation Test: Turn dimmer or other control device to the "ON" position. Normal & emergency lights should turn on. Reduce dimmer to ~50%, normal and emergency lights should dim together. Turn room switch or control to the "OFF" position. Normal lights should turn off immediately. If ATS slide switch is ON, emergency lights should stay on for at least 2.5 seconds. If ATS slide switch is OFF, emergency lights should turn off immediately.
- 4) Emergency Operation Test: Press and hold test button, emergency lights should illuminate at full brightness until test button is released.

Maintenance

No maintenance is required to keep the EPC functional. However, regular testing should be performed when the lamps or ballasts have been replaced or when remodeling has taken place.

Single Line Drawings

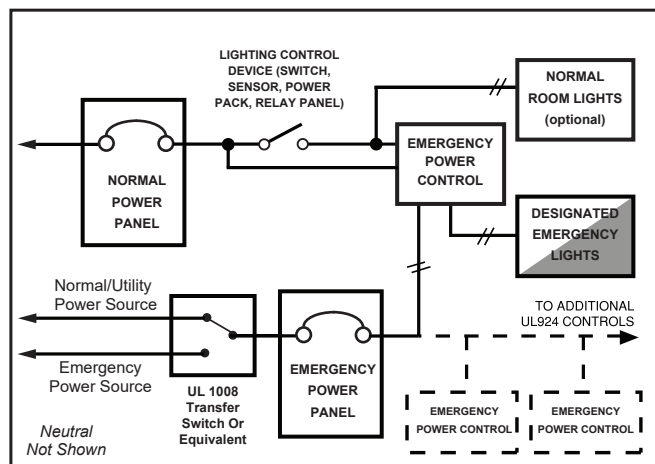
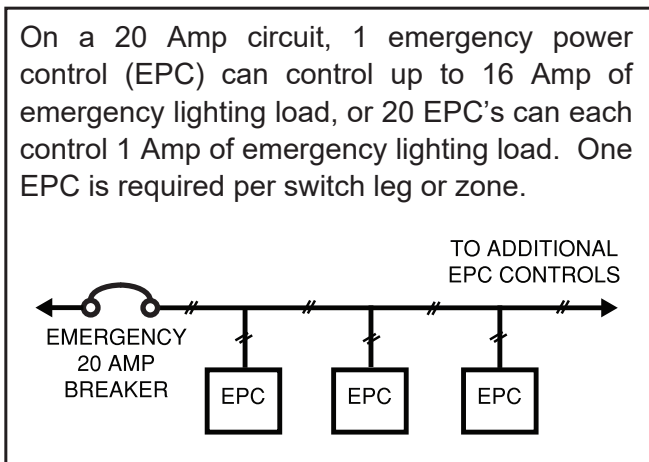

Wiring Diagram #1 (Suggested): A common dimmer controls both normal and emergency lighting in a space. Upon loss of normal power, the emergency lighting comes on at full brightness regardless of dimmer position.

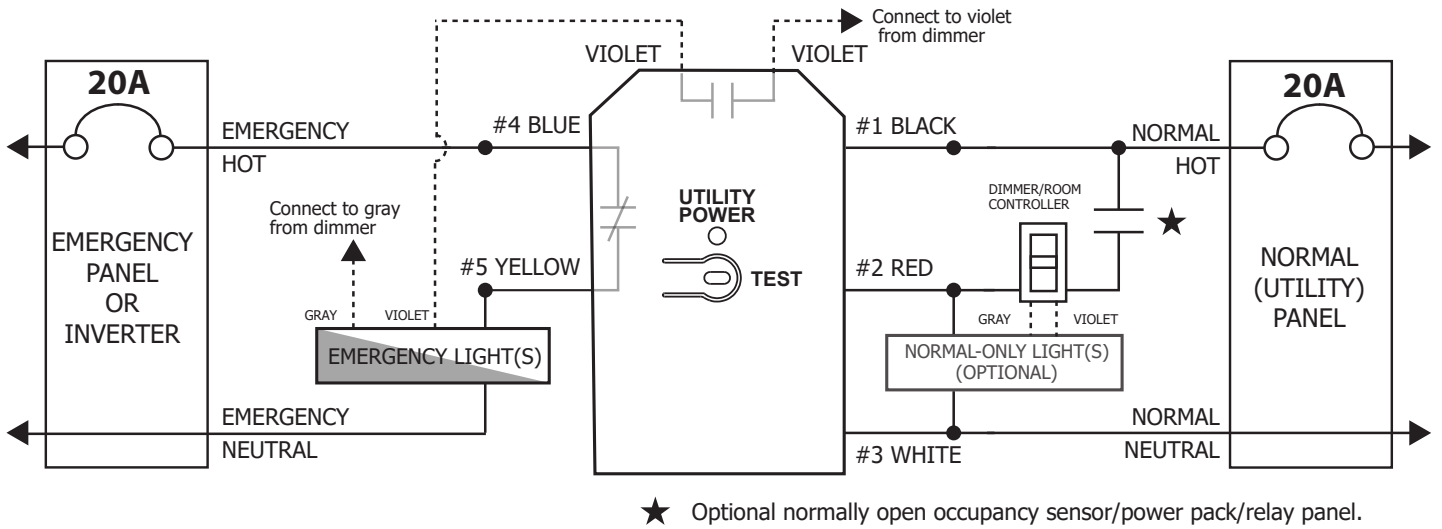

Wiring Diagram #2 (Shunt): A dedicated dimmer controls emergency lighting in a space. Upon loss of normal power, the emergency lighting comes on at full brightness regardless of dimmer position.

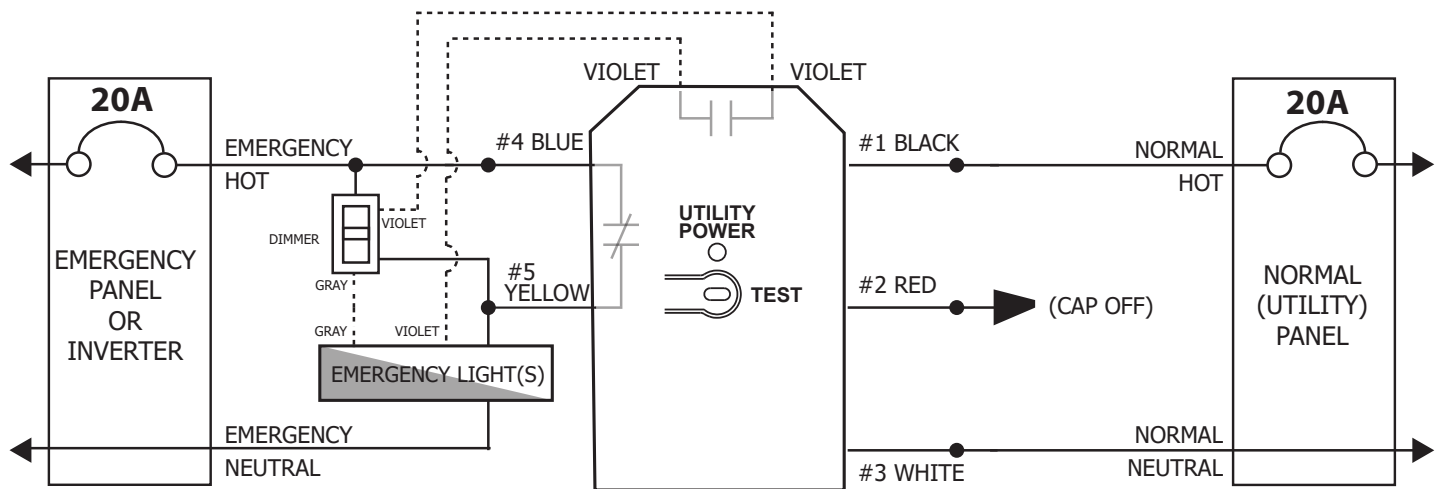

FREQUENTLY ASKED QUESTIONS:

Do I need a separate normal and emergency ballast/driver?

NO, the emergency light only needs a single ballast/driver. The Normal-Only light(s) shown are separate light fixtures that you want to control with the same switch, but which do not serve as emergency lighting during a power interruption.

Can I use the EPC-A-2-D with 3-way dimmers?

YES

Why is my EPC-A-2-D buzzing/humming/chattering?

This can occur with some dimmers when they do not have enough load on them. Changing to Wiring Diagram #2 should eliminate this issue, contact LVS for further assistance.

How do I wire the EPC-A-2-D with DALI/EcoSystem loads?

4 Please check this link: <http://www.lvscontrols.com/assets/EPC2DDALI.pdf>