

ISI - EPC-A-2

UL LISTED EMERGENCY POWER CONTROL
INTENDED FOR USE WITH SWITCHING CONTROLS

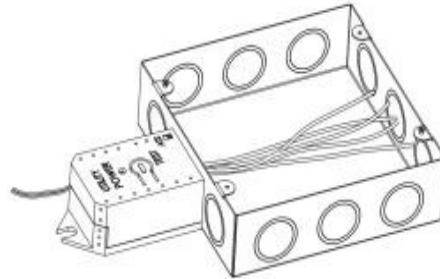

**Mounting ears can be quickly removed with pliers to permit mounting using threaded hub.*



2-1/2"(L) x 1-5/8"(W) x 1-3/8"(H)
(excluding ears/hub)

Field wiring leads: 7.5"

APPLICATION

In the past, emergency lights were kept on 24 hours a day to meet life safety codes. Now, you can use a UL 924 listed Emergency Power Control, Model EPC-A-2, to convert normal light fixtures into approved emergency lights. The EPC-A-2 saves energy and money while ensuring compliance with both life safety and energy codes.

During normal operation, the same switch, occupancy sensor, relay panel, or lighting control can switch normal and emergency fixtures on and off simultaneously.

During a utility power interruption, the EPC-A-2 automatically bypasses the normal lighting controls, turning the emergency lights ON, regardless of switch position.

The EPC-A-2 boasts a universal mount design with ears; allowing the device to be nipple, fixture, panel or box mounted. This enables the EPC-A-2 to adapt to the application requirements.

FEATURES

- Fire Alarm Override/Remote Test Switch input
- Utility Power Indicator LED
- Universal Mount Design:
Contractor friendly design hub design similar to industry standard power packs for quick and easy installation.
- Unique, Patented Automatic Diagnostic
When the room switch is turned off, the EPC-A-2 will run a 2.5 self-test routine, verifying that the emergency power source was available and that the EPC-A-2, ballast, and lamp(s) are all functioning correctly. This feature eliminates the need for time-consuming and costly manual monthly testing and is approved for this purpose. This also allows the unit to be installed in remote or inaccessible locations, because the unit does not rely on access to its manual test switch. Field selectable via "ATS" slider switch.



SINGLE LINE DRAWING

On a 20 Amp circuit, 1 emergency power control (EPC) can control up to 16 Amp of emergency lighting load, or 20 EPC's can each control 1 Amp of emergency lighting load. One EPC is required per switch leg or zone.

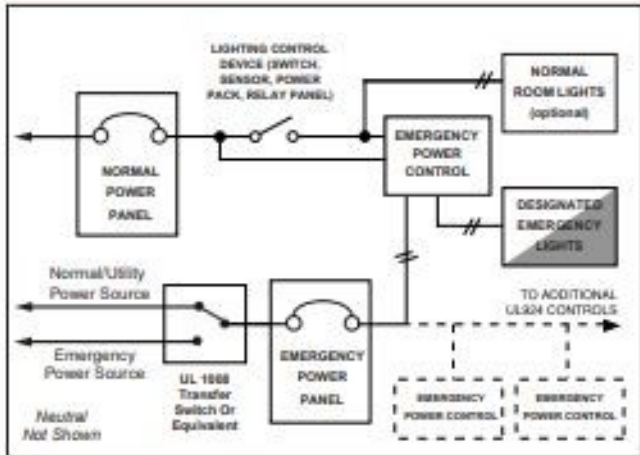
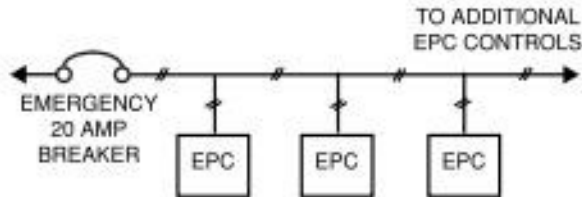

WIRING DIAGRAM

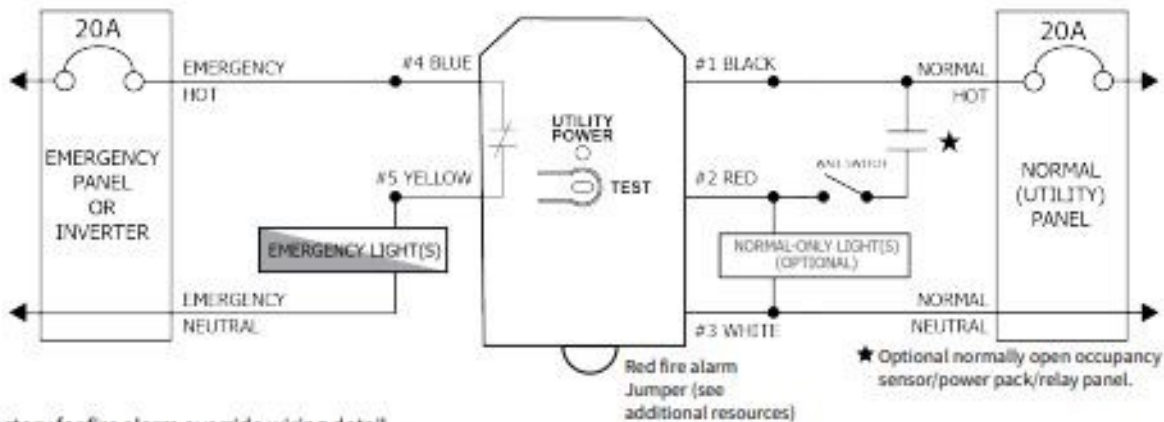

Contact factory for fire alarm override wiring detail.

SPECIFICATIONS

| | | |
|---------------------------|---------------------|--|
| ELECTRICAL RATINGS | MODEL NUMBER | EPC-A-2 |
| | SENSING VOLTAGE | 120-240/277V |
| | LOAD VOLTAGE | 120-277V |
| | BALLAST/DRIVER LOAD | 16 Amp Electronic Ballast/LED Driver/General Use 5 Amp Magnetic Ballast |
| | INCANDESCENT LOAD | 1800W (120V) / 3000W (277V) Normally Closed Output Contact |
| | WARRANTY | 5 Year Limited Warranty |

| | | |
|-------------------|------------------------------|---|
| MECHANICAL | MOUNTING | Nipples on 1/2" KO |
| | PLENUM RATING | Plenum Rated. Tested to UL2043. UL94-5VA. |
| | SHIPPING WEIGHT/COLOR | 4 oz. / Black |
| | TEMPERATURE | -40°C - 60°C (40°F - 140°F) |
| | BODY SIZE (without Hub/Ears) | 2-1/2" x 1-5/8" x 1-3/8" |
| | BODY SIZE (with Hub/Ears) | 3-5/8" x 1-5/8" x 1-3/8" |